

# Prosjektstatus

# Sperro

- litt historie
- status i dag
- bruker erfaring
- neste sesong
- utfordringer

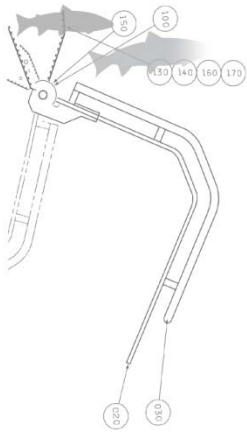



# Litt om Sperro historien

2011

Jon Edvards  
festesnor idé

Fungerte  
ikke helt

Nytt prinsipp  
testes på Røst

2012

Prototype test  
på Røst

Produksjon  
7 maskiner

7 uker på Røst  
= 1 maskin

2013

Nytt verktøy  
testes på Myre

Produksjon  
nye verktøy

8 uker i V + L + R  
= nesten 5 maskin

2014

# Problemet i 2012?

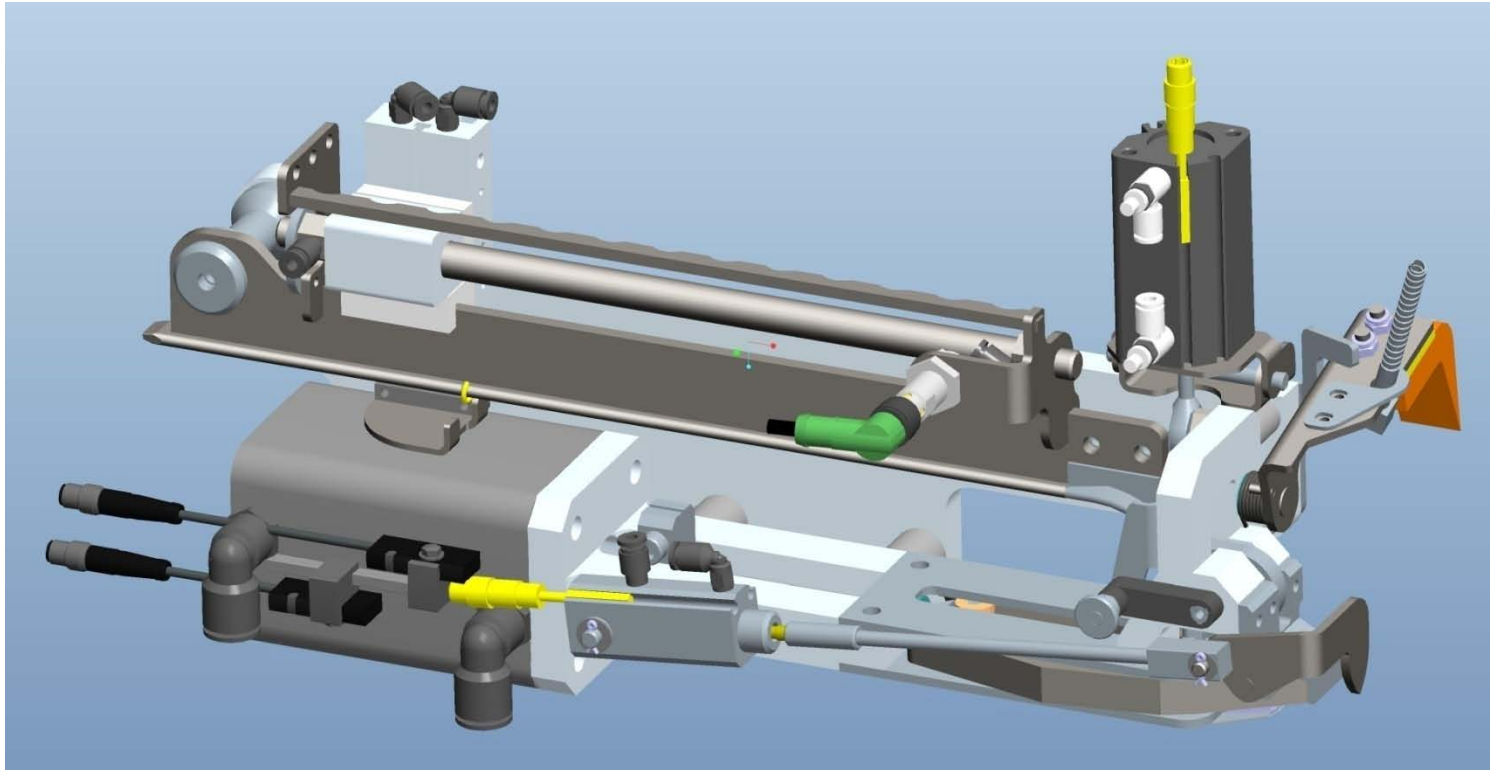
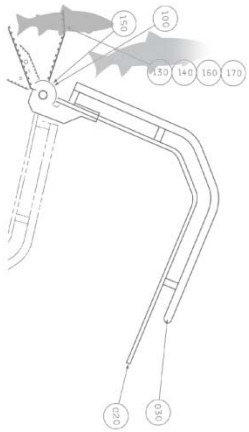

**Problemene i verktøyet medførte feilbedømming av ringer og tau**

# Usikkerheter i 2013?

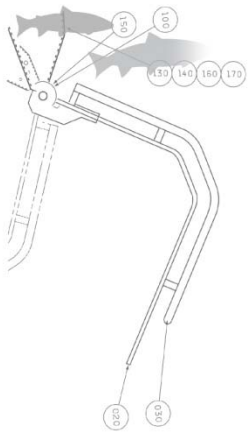

Det er mange varianter av tau og ringer der ute. Noe kan brukes i maskinen noe må "kastes".

# Hva skjedde denne sesongen?

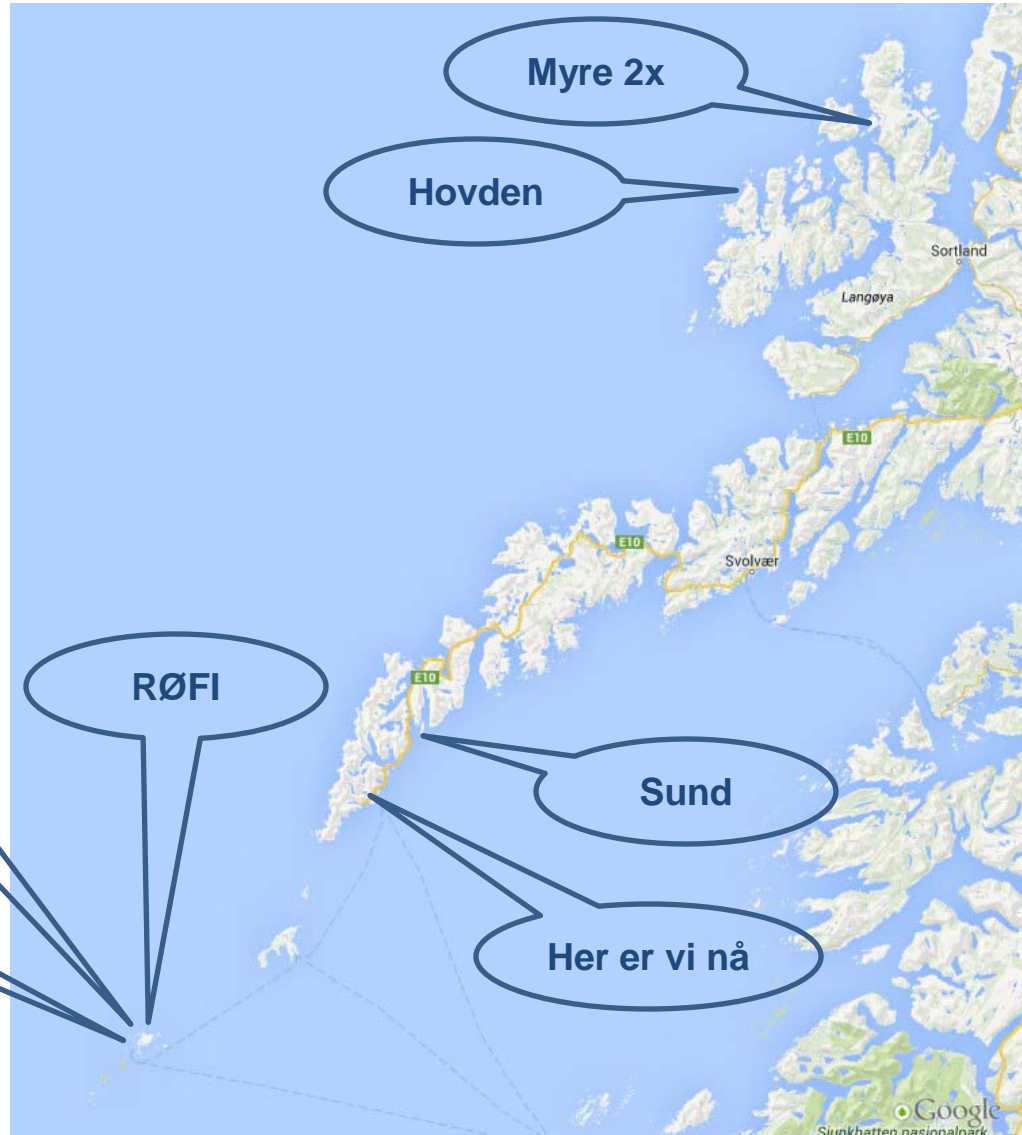
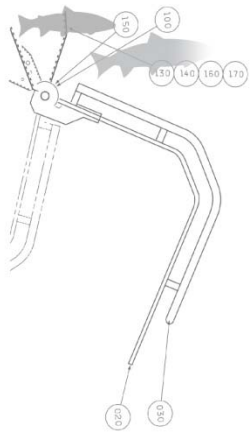



# Mye kjøring mellom de 4 maskinen

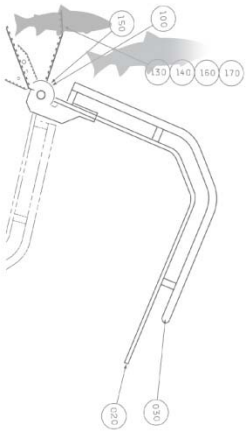

# Hva var problemene denne sesongen?

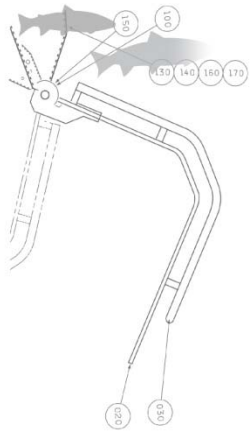

Det ble gjennomført ca 40 oppgradering, store og små detaljer gjennom sesongen.

- mindre maskinmontasje problemer
  - vanninntregning i plugger og kontakter
  - små justeringer i verktøy
  - noen sensor feil
- 
- vask og sensorer er en utfordring
  - fjern diagnose er nødvendig
- Så dukket det opp slitasje problemer i klemkjeftene**

# Slitasje på klemkjefter

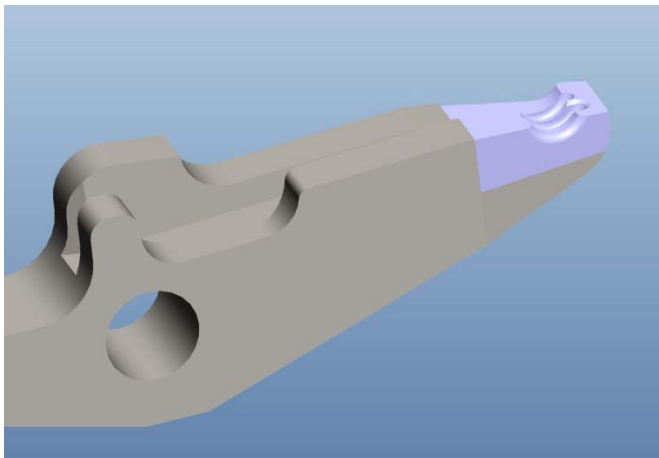
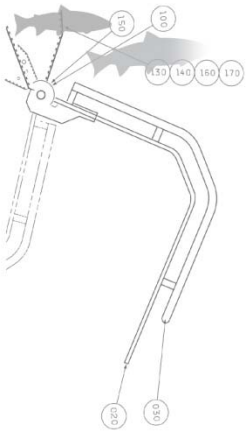





# Bruker erfaringer

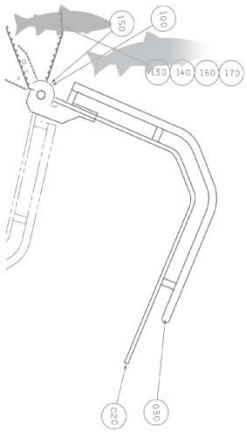

# Frem til neste sesong

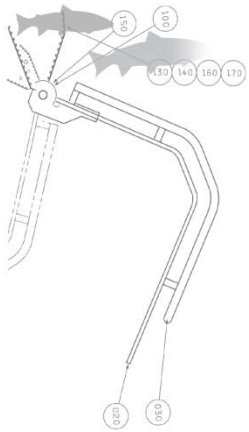

- oppgradering av de 2 siste maskiner på Røst
  - alle deler på lager
- nye klemkjefter på alle maskiner
  - må produseres
- produsere riktig tau med god fleksibilitet og knudrete overflate.
- vaskesikker sensorer kobling

# Den store utfordringen

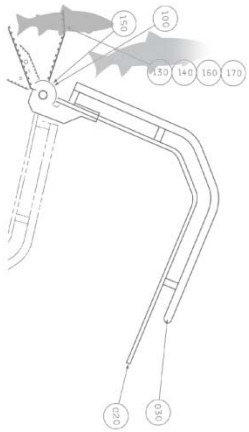

**Oppgaven med å utvikle Sperro maskinen ble for kostbar og selskapet makter ikke å fullføre jobben uten en form for finansiell hjelp.**

## Prosjekt regnskap og prognose

<b>Tilskudd: FHF/IN:</b>	<b>675'</b>
<b>Utviklingskostnader SFA</b>	<b>1.500'</b> frem til 31.12.12
	<b>1.200'</b> frem til 31.12.13
	<b>250'</b> frem til 31.05.14
	<b>300'</b> frem til 31.12.14
	<b>250'</b> frem til 30.04.15
<b>Sum utviklingskostnader</b>	<b>3.500'</b> (7 serie)

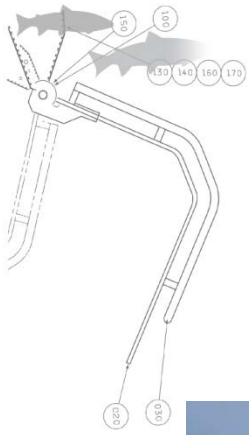

# Et praktfullt syn

